

CAD FILE:

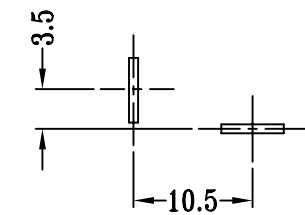
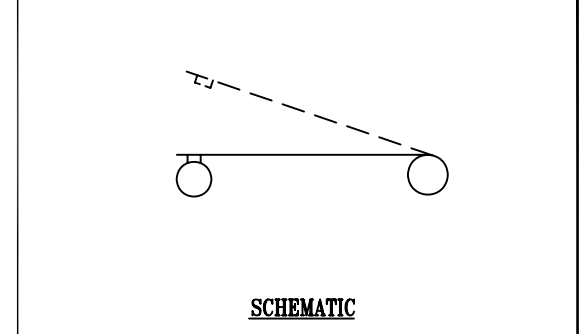
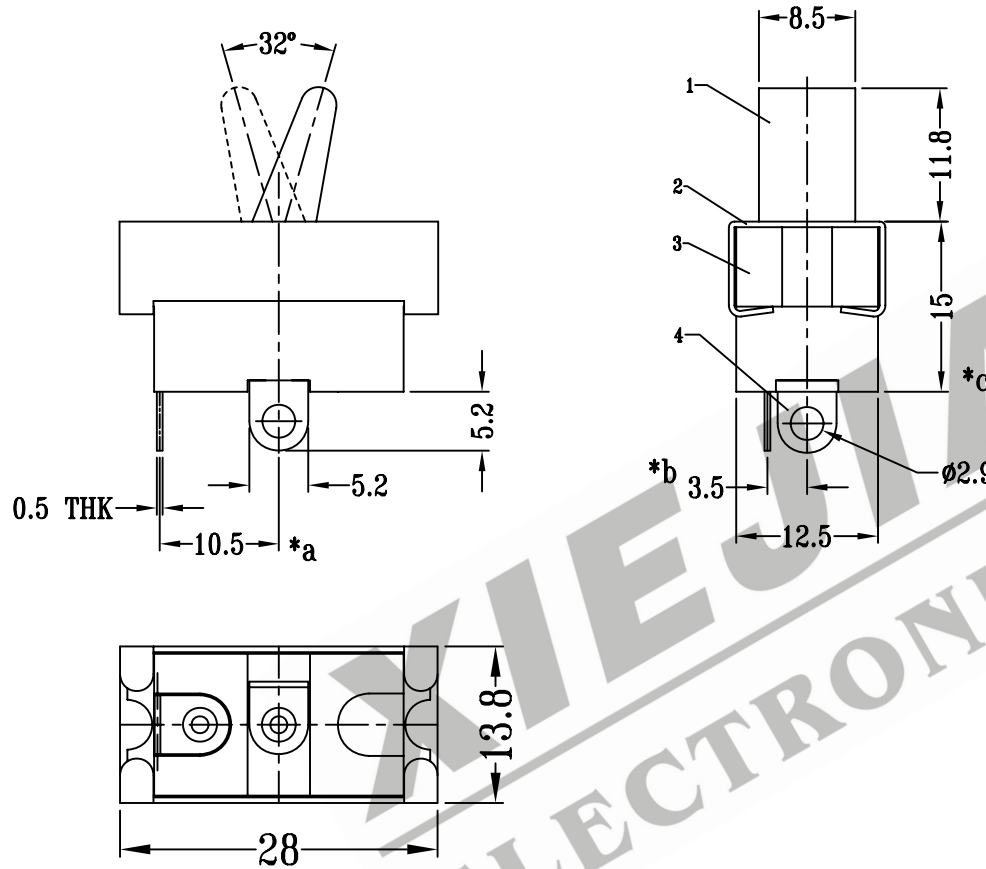

| | | | | |
|-----|-----------|-------------|------|-----------|
| 11 | CONTACT D | BRASS STRIP | 1 | NATURAL |
| 10 | CONTACT C | COPPER | 1 | Ag PLATED |
| 9 | BAR | BRASS | 1 | NATURAL |
| 8 | SPRING | STEEL WIRE | 1 | TEMPER |
| 7 | SUPPORT | BRASS | 1 | NATURAL |
| 6 | CONTACT B | COPPER | 1 | NATURAL |
| 5 | CONTACT A | COPPER | 1 | Ag PLATED |
| 4 | TERMINAL | BRASS STRIP | 2 | NATURAL |
| 3 | CASE | PC | 1 | BLACK |
| 2 | FRAME | STEEL STRIP | 1 | Zn PLATED |
| 1 | KNOB | ABS | 1 | BLUE |
| NO. | PART NAME | MATERIAL | QTY. | FINISHING |

| | | | | | |
|---|------|--------------------------------------|---------------------------|-----------|-----------|
| TOLERANCE UNLESS SPECIFIED | | SHENZHEN XIEJIA ELECTRONICS CO.,LTD. | | | |
| WITHIN: 1.5±0.1mm OVER : 1.5±0.2mm | | | | | |
| ISSUE | DATE | DESCRIPTIONS | | APPD. | |
| TITLE : ROCKER SWITCH | | UNIT : MM | DRWG NO.: XJ-DR-RS1138-00 | | |
| MODEL: RS-1138 | | SCALE: 3:2 | DWN. | ZHOUYU | 2004-3-10 |
| ALL MATERIALS MUST BE COMPLIANT TO ROHS | | | CHK'D | FANGYING | 2004-3-10 |
| | | | APPD. | KANGXINAN | 2004-3-10 |

注:带*表示关键尺寸(3个)